

KINAX WT 717

Programmable Transmitter for Angular Position

Ruggedized version



Application

The **KINAX WT 717** (Fig. 1) converts the angular position of a shaft into a **load-independent** direct current signal, proportional to the angular position. The unit is **contact free**. The robust housing has made this unit ideal for machines, ship building, transport, construction of vehicles and in the chemical industry.



Fig. 1. KINAX WT 717 with foot.

Features / Benefits

- Measuring range, sense of rotation, characteristic, switching point and other additional functions programmed using PC / Simplifies project planning and engineering, short delivery times, low stocking

Measured variable	Measuring range limits
Angular position	Programmable between 0 ... 10 and 0 ... 50 or 0 ... 50 and 0 ... 350 α°

- Simulation of measured values / The testing of the subsequent device chain is already possible during the installation phase
- Measured value acquisition / Display of the instantaneous value and a trend graph of the measured value on the screen
- Adjustment / Independent fine adjustment of the analog output, zero position and measuring range
- Characteristic of the output value / Programmable as a linear, V-characteristic, or any characteristic curve
- The shaft can be turned through full
- Patented measuring method
- Ancillary unit in ruggedized housing / Vibration and shock-resistant, for applications on large machines and in ship building

The angular deflection α of the device to be measured is transferred to the rotor R of the differential screen capacitor with the aid of a mechanical coupling. It is then converted into a change of capacitance proportional to the angle.

All changes to the position of the rotor result in a change in the capacitance at the input to the microprocessor. This is transformed into a DC current signal proportional to the measured value.

Layout and mode of operation

The transmitter consists of 2 main parts: the differential screen capacitor D and the electronic circuitry E (Fig. 2).

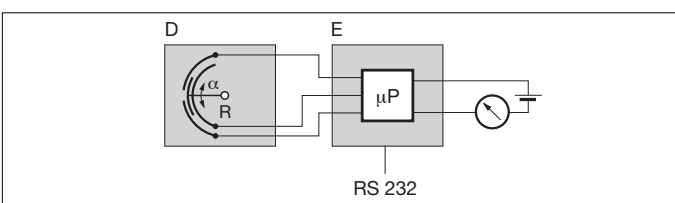

Fig. 2. Block diagram.

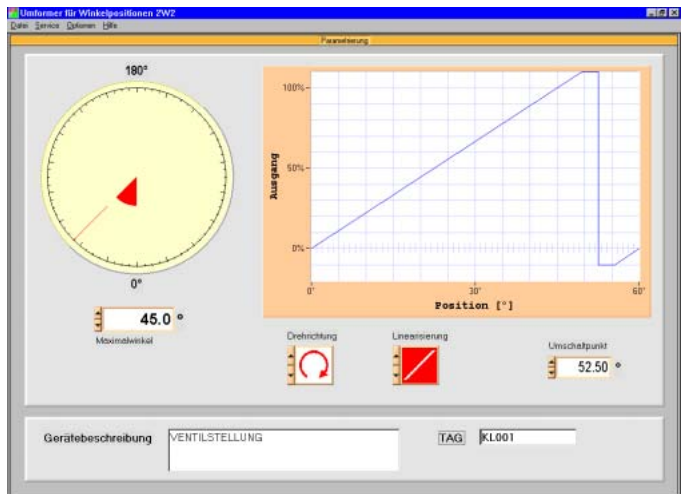

Fig. 3. Print screen example of the menu-controlled programming software.

KINAX WT 717

Programmable Transmitter for Angular Position

Programming

A PC, the programming cable PK 610 plus ancillary cable and the configuration software 2W2 are required to program the transmitter. (Details of the programming cable and the software are to be found in the separate data sheet: PK 610 Le.)

The connections between "PC ↔ PK 610 ↔ KINAX WT 717" can be seen from Fig. 4. The transmitter can be programmed either with or without the power supply connected.

The software 2W2 is supplied on one CD and runs under Windows 95 or higher.

The programming cable PK 610 adjusts the signal level between the PC and the transmitter KINAX WT 717.

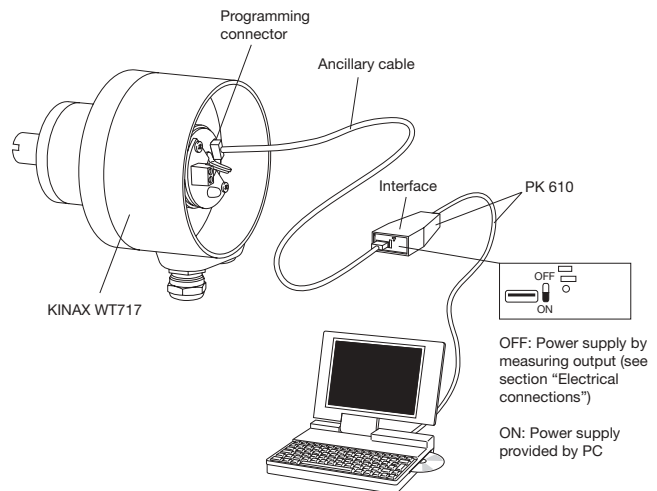

Fig. 4. Example of the set-up for programming a KINAX WT 717 without the power supply. For this case the switch on the interface must be set to "ON".

Technical data

General

Measured quantity: Angle of rotation α \curvearrowright °
 Measuring principle: Capacitive method
 Differential screen capacitor with contact-free, non-wearing positional pick-up. Drive shaft fully rotatable without stops (patented measuring method)

Current limitation: I_A max. 40 mA
 Standard range: 4...20 mA, two-wire
 External resistance (load): $R_{\text{ext}} \text{ max. [k}\Omega\text{]} = \frac{H \text{ [V]} - 12 \text{ V}}{I_A \text{ [mA]}}$
 H = DC power supply
 I_A = End value of output variable

Measuring input

Measuring range of rotation angle:
 Programmable between
 0 ... 10 and 0 ... 50 \curvearrowright ° (without gear)
 0 ... 20 \curvearrowright ° and 0 ... 222 turns (with additional gear)
 or
 0 ... 50 and 0 ... 350 \curvearrowright ° (without gear)
 0 ... 100 \curvearrowright ° and 0 ... 1555 turns (with additional gear)

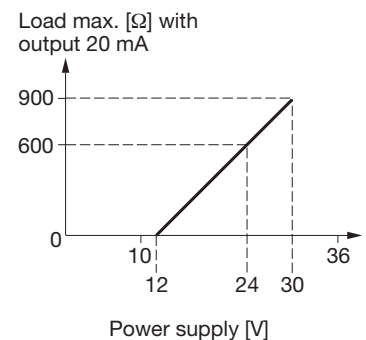

Drive shaft diameter: 19 mm
 Frictional torque: Approx. 25 Ncm
 Sense of rotation of the drive shaft: Programmable for sense of rotation clockwise or counterclockwise

Residual ripple in output current: < 0.3% p.p.
 Response time: < 5 ms

Measuring output

Power supply: H = 12 to 33 V DC
 Protected against wrong polarity
 Output variable I_A : Load-independent DC current, proportional to the input angle
 Zero point correction: Approx. \pm 5%
 Span adjustment: Approx. \pm 5%

Programming connector

Interface: Serial interface

Accuracy data

Reference value: Measuring span
 Basic accuracy: Error limits at reference conditions $\leq \pm$ 0.5%
 Reproducibility: < 0.2%

KINAX WT 717

Programmable Transmitter for Angular Position

Reference conditions

Ambient temperature	23 °C ± 2 K
Power supply	18 V DC
Output burden	0 Ω
Adjustments	350° version measuring range > 50...350° characteristic linear
	50° version measuring range ≥ 10...50° characteristic linear

Influence effects (maxima)

(included in basic error)	
Dependence on external resistance ΔR_{ext} max.	± 0.1%
Power supply influence	± 0.1%
Additional error (maxima)	
Temperature influence (– 25...+ 75 °C)	± 0.2% / 10 K
Bearing play influence	± 0.1%

Additional errors (cumulative)

Output characteristic	Definitions	Device version	Additional error
simple "V" characteristic 	Angle max. = MW Angle min. = 0°	350°	$f = \left(\frac{0.18^\circ}{MW} \times 100 \right)$
		50°	$f = \left(\frac{0.05^\circ}{MW} \times 100 \right)$
"V" characteristic with offset 	MS = (angle max.) – (angle min.) Angle max. = ± final angle Angle min. = > 0°	350°	$f = \left(\frac{0.25^\circ}{MS} \times 100 \right)$
		50°	$f = \left(\frac{0.09^\circ}{MS} \times 100 \right)$
any characteristic 	MS = (angle max.) – (angle min.)	350°	$f = \left(\frac{0.25^\circ}{MS} \times 100 \right)$
		50°	$f = \left(\frac{0.09^\circ}{MS} \times 100 \right)$

KINAX WT 717

Programmable Transmitter for Angular Position

Mechanical withstand

Permissible vibrations: (without additional gear) 0...200 Hz, 10 g continuous, 15 g for 2 h
200...500 Hz, 5 g continuous, 10 g for 2 h

Shock: 3 × 50 g every 10 impulses in all 3 axes

Permissible static load on the shaft: Max. 1000 N (radial)
Max. 500 N (axial)
If subjected to vibration the shaft load should be as low as possible to ensure optimum life of the bearing

Mounting position: Any

Housing data

Material of housing: Steel
(main part) Finish QPQ (nitro-carbonated)

Material of back: **Metal** (aluminium)

Material of cable gland: Metal

On the rear (cover) there are 2 screw terminals and the programming connector (Fig. 5). The screw terminals accept gauges up to max. 1.5 mm² and are accessible after removing the cover.

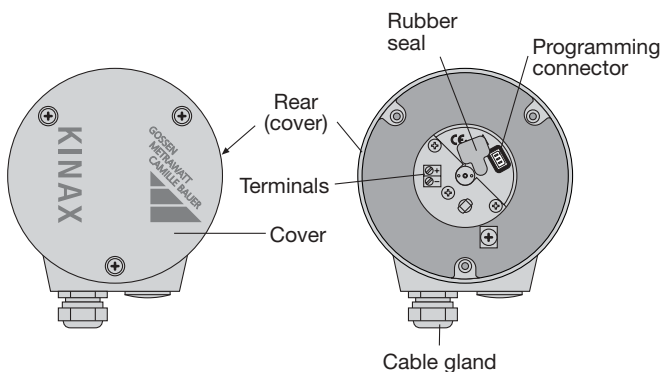

Fig. 5. KINAX WT 717 with screw terminals, programming connector and cable gland.

Mounting: Directly (instrument without foot, without flange)

Mounting with foot

Mounting with flange

Weight: See Table 1

Table 1:

Weight	Description of parts
Approx. 2.9 kg	KINAX WT 717 without additional gear (also without foot or without flange)
Approx. 3.9 kg	KINAX WT 717 with additional gear (but without foot or without flange)
0.5 kg	Foot (on its own)
0.5 kg	Flange (on its own)

Regulations

Electromagnetic compatibility: The standards DIN EN 50 081-2 and DIN EN 50 082-2 are observed

Housing protection: IP 67 acc. to EN 60 529

Test voltage: 500 V_{eff}, 50 Hz, 1 min.
all electrical connections against housing

Impulse voltage withstand: 1 kV, 1.2/50 μs, 0.5 Ws
IEC 255-4, Cl. II

Admissible common-mode voltage: 100 V, 50 Hz

Environmental conditions

Climatic rating: Standard version
Temperature -25 to + 75 °C
Annual mean relative humidity ≤ 90%
or

Version with improved climatic rating
Temperature - 40 to + 75 °C
Annual mean relative humidity ≤ 95%

Transportation and storage temperature: - 40 to 80 °C

Basic configuration

The transmitter KINAX WT 717 is also available already programmed with a **basic** configuration which is especially recommended in

cases where the programming data is not known at the time of ordering (see "Table 2: Specification and ordering information", feature 4).

Basic configuration:

Order Code	Mechanical angle range	Measuring range	Switching point	Sense of rotation	Characteristic of output variable
717 - 1100 0X0X XXXX X	50°	0 ... 50°	55°	Clockwise	Linear
717 - 1200 0X0X XXXX X	350°	0 ... 350°	355°	Clockwise	Linear

KINAX WT 717

Programmable Transmitter for Angular Position

Table 2: Specification and ordering information

Order Code 717 -			
Features, Selection	*SCODE	no-go	
1. Version of the transmitter 1) Standard			↑ ↑ ↑ ↑ ↑
2. Mechanical angle range 1) Angle range to 50° 2) Angle range > 50 to 350°			1 1 2
3. Sense of rotation 0) Sense of rotation clockwise 1) Sense of rotation counterclockwise 2) For "V" characteristic Lines 1 and 2: Not possible for transmitters with basic configuration	D E F		. . . 0 1 2
4. Measuring range 0) Basic configuration, programmed 9) [°angle], 0 to final value / switching point: Z) "V" characteristic [± °angle], min/max.: Specify in line 9: Final value ≥ 10 to 50° with angle range ≥ 50°, > 50 to 350° with angle range > 350° Switching point > Final value, max. 60° with angle range ≥ 50°, > Final value, max. 360° with angle range > 350° ≥ 105% final value with non-linear characteristic (Lines 1 to 4 in feature 5) Specify in line Z: Minimal value > 0 Maximal value ≥ 25 with angle range ≥ 50°, Span (max. value – min. value) ≥ 5°; > 25 to 175 with angle range > 350°, span ≥ 25° symmetrical about the center line, e.g. [± angle], min/max.: 15/120 correspond: – 120 to – 15 to 0 to 15 to 120° angle (input) + 20 to 4 to < 4 to 4 to +20 mA (output)	G	EF F DE 0 9 Z
5. Characteristic of output variable 0) Characteristic linear 1) Function X to the power of 1/2 2) Function X to the power of 3/2 3) Function X to the power of 5/2 4) Customized Lines 1 to 4: Not possible with "V" characteristic Line 4 (on inquiry): Give an algorithm or fixed points (23 values in 5% steps from – 5% to 105% of the measuring range, output continuously variable – 10 to 110%)		FG FG FG FG 0 1 2 3 4
6. Test certificate 0) Without test certificate D) Test certificate in German E) Test certificate in English		 0 D E

Continuation of table 2 see next page!

KINAX WT 717

Programmable Transmitter for Angular Position

Order Code 717 -			
Features, Selection	*SCODE	no-go	
7. Marking the system zero position			
0) System zero position not marked			0
1) System zero position marked		G	1
8. Climatic rating			
0) Standard climatic rating			. 0
1) Improved climatic rating			. 1
9. Mounting mode			
0) Mounting without foot/flange			. . 0
1) With foot (mounted)			. . 1
2) With flange (mounted)			. . 2
10. Marine version			
Without			. . . 0
Version GL ("Germanischer Lloyd")			. . . 1
11. Vibration resistance			
Standard vibration resistance		 0
Increased vibration resistance	H	 M
12. Additional gear 2:1 to 144:1			
Without additional gear		 0
Transformation 2:1	J	FH 1
Transformation 4:1	J	FH 2
Transformation 5:1	J	FH 3
Transformation 6:1	J	FH 4
Transformation 8:1	J	FH 5
Transformation 10:1	J	FH A
Transformation 12:1	J	FH B
Transformation 12,5:1	J	FH C
Transformation 15:1	J	FH D
Transformation 16:1	J	FH E
Transformation 20:1	J	FH F
Transformation 22:1	J	FH G
Transformation 24:1	J	FH H
Transformation 25:1	J	FH J
Transformation 30:1	J	FH K
Transformation 32:1	J	FH L
Transformation 36:1	J	FH M
Transformation 40:1	J	FH N
Transformation 50:1	J	FH O
Transformation 60:1	J	FH P
Transformation 64:1	J	FH Q
Transformation 72:1	J	FH R
Transformation 75:1	J	FH S
Transformation 80:1	J	FH T
Transformation 100:1	J	FH U
Transformation 120:1	J	FH V
Transformation 144:1	J	FH W

KINAX WT 717

Programmable Transmitter for Angular Position

Order Code 717 -	*SCODE	no-go	
Features, Selection			
13. Additional gear 150:1 to 1600:1			
Without additional gear			
Transformation 150:1		FHJ	0
Transformation 160:1		FHJ	1
Transformation 180:1		FHJ	2
Transformation 200:1		FHJ	3
Transformation 240:1		FHJ	4
Transformation 250:1		FHJ	A
Transformation 300:1		FHJ	B
Transformation 330:1		FHJ	C
Transformation 360:1		FHJ	D
Transformation 375:1		FHJ	E
Transformation 400:1		FHJ	F
Transformation 450:1		FHJ	G
Transformation 480:1		FHJ	H
Transformation 500:1		FHJ	J
Transformation 550:1		FHJ	K
Transformation 600:1		FHJ	L
Transformation 660:1		FHJ	M
Transformation 720:1		FHJ	N
Transformation 750:1		FHJ	O
Transformation 800:1		FHJ	P
Transformation 880:1		FHJ	Q
Transformation 900:1		FHJ	R
Transformation 1000:1		FHJ	S
Transformation 1024:1		FHJ	T
Transformation 1200:1		FHJ	U
Transformation 1600:1		FHJ	V
			W

* Lines with letter(s) under "no-go" cannot be combined with preceding lines having the same letter under "SCODE".

Electrical connections

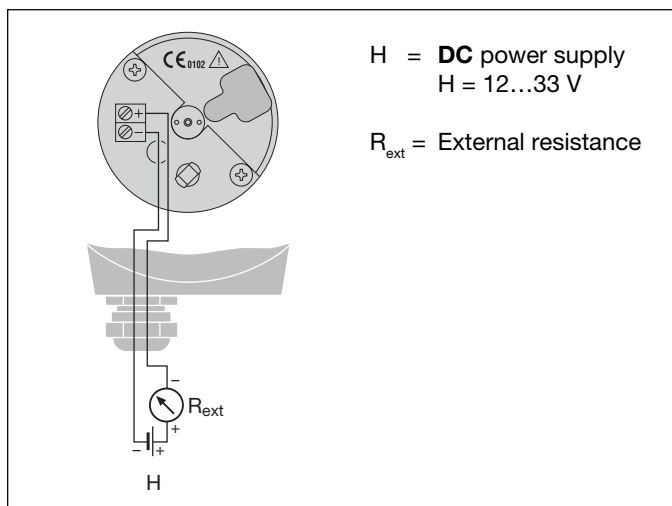

Standard accessories

- 1 Operating Instructions in three languages: German, French, English
- 1 Blank label

KINAX WT 717

Programmable Transmitter for Angular Position

Table 4: Accessories and spare parts

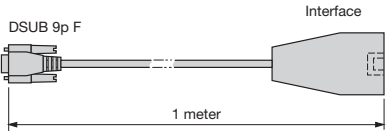
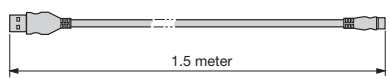
Description	Order No.
Programming cable PK 610 	137 887
Ancillary cable 	141 440
Configuration software 2W2 Windows 95 or higher on CD in German and English (Download free of charge under http://www.camillebauer.ch) In addition, the CD contains all configuration programmes presently available for Camille Bauer products	146 557
Operating Instructions WT 717 Bd-f-e in German, French and English	151 259

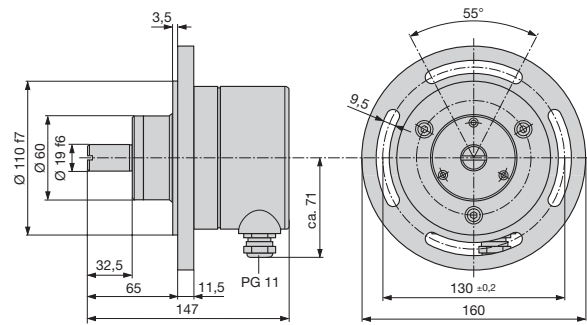

Fig. 8. KINAX WT 717 with flange.

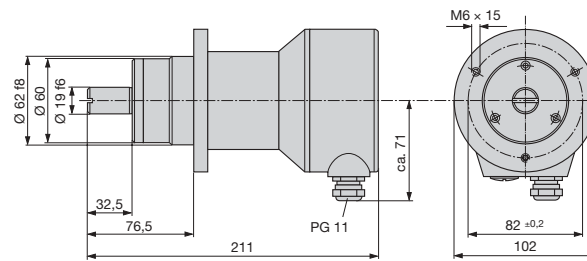

Fig. 9. KINAX WT 717 with additional gear.

Dimensional drawings

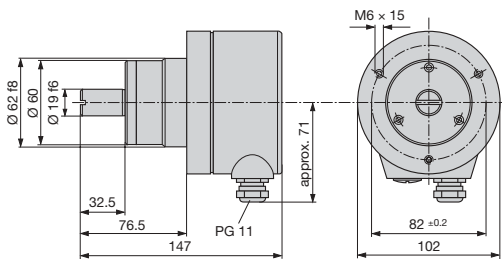

Fig. 6. KINAX WT 717.

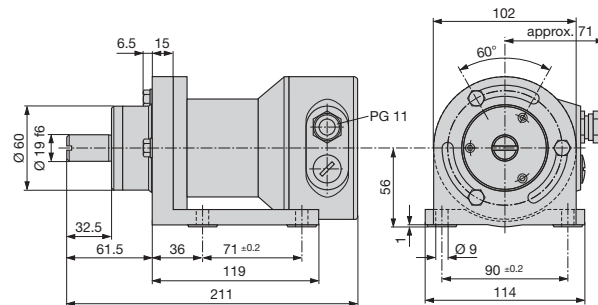

Fig. 9. KINAX WT 717 with additional gear and foot.

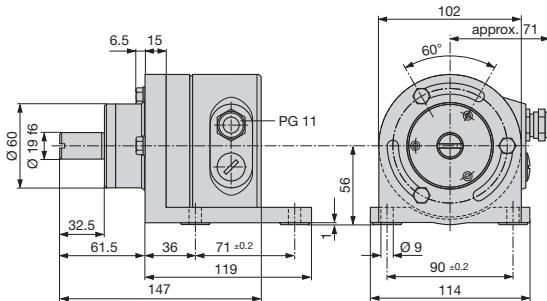

Fig. 7. KINAX WT 717 with foot.

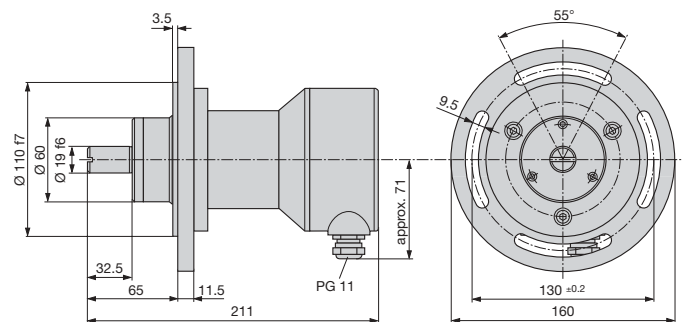

Fig. 10. KINAX WT 717 with additional gear and flange.